

PCB-貼標機

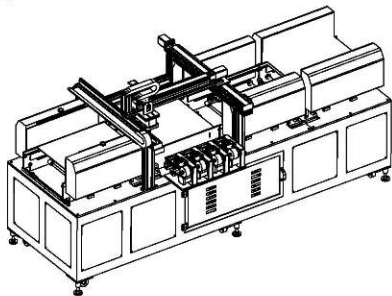

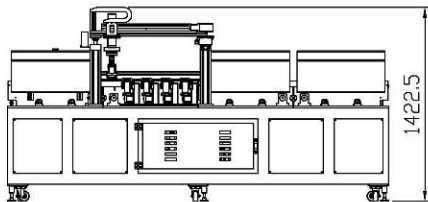

硬碟零件檢查機

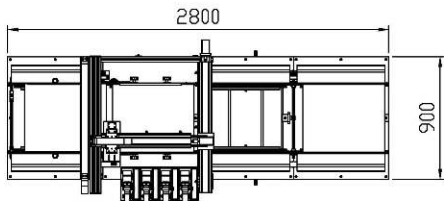
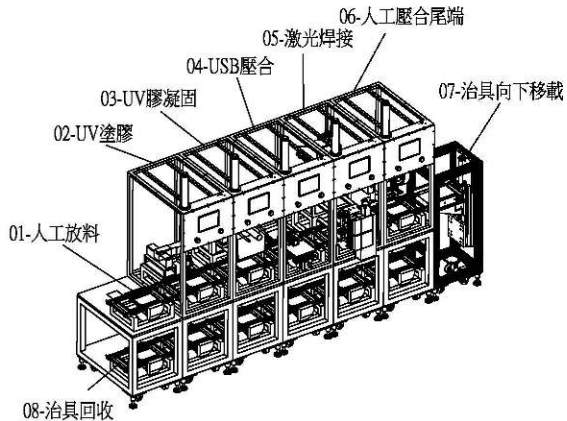
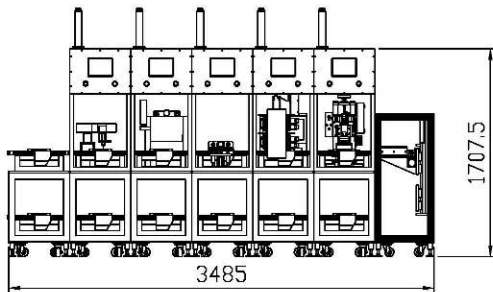
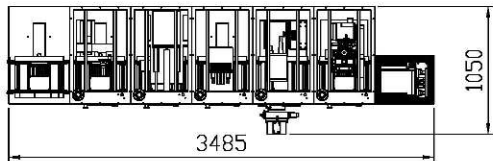
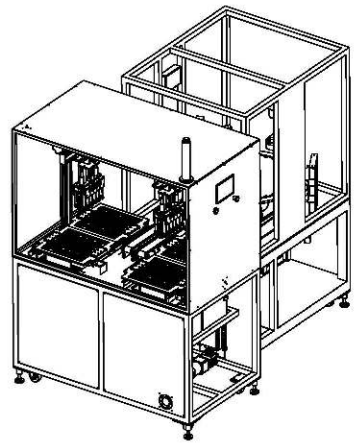
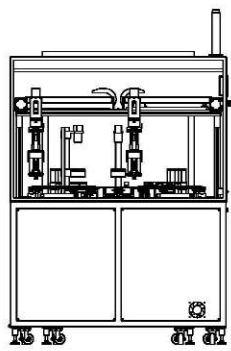
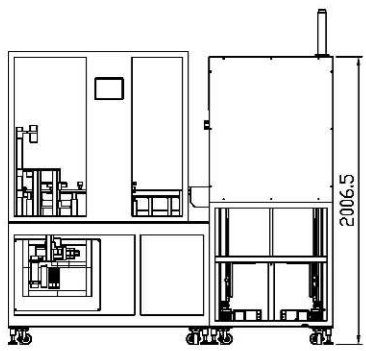
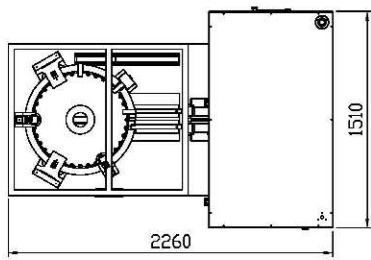

循環系統

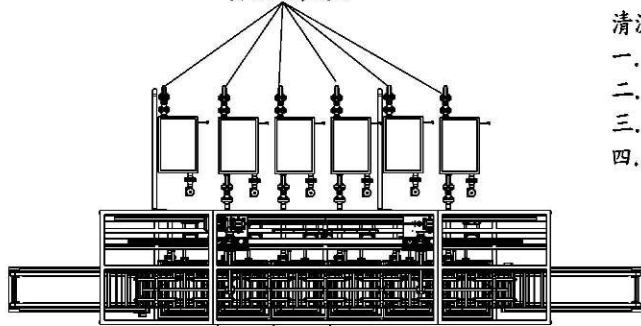

清洗機規格

- 一. 機台面積: 8388mm長 X 2500mm寬 X 2660mm高.
- 二. 產能 : 一次產出80pcs.
- 三. 有化學填加劑的桶子, 材質為SUS-316.
- 四. 其它零件皆為SUS-304.

- 8-出料輸送帶
- 8-直接噴水
TIME=5MIN
不需過濾
- 7-超音波洗淨
頻率: 72KHZ
TIME=5MIN
TEMP=45±5°
需循環回流
- 6-超音波洗淨
頻率: 72KHZ
TIME=5MIN
TEMP=45±5°
需循環回流
- 5-超音波洗淨
頻率: 72KHZ
TIME=5MIN
TEMP=45±5°
需循環回流
- 4-直接噴水
TIME=5MIN
不需過濾
- 3-直接噴水
去油垢
TIME=5MIN
TEMP=45±5°
需循環回流
- 2-機械手
吊料架
- 1-進料輸送帶

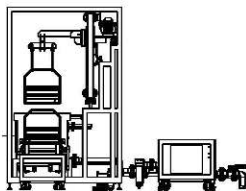
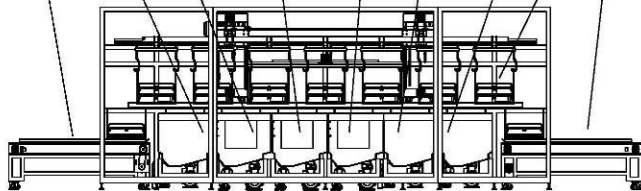

IN LINE 自動組立機

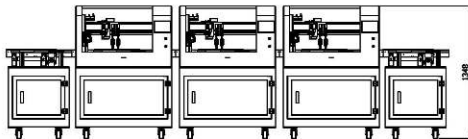
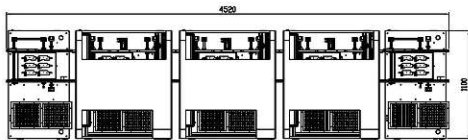
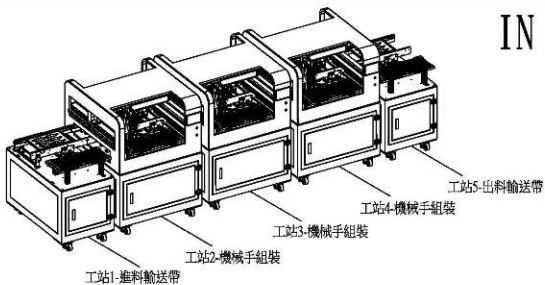

IN LINE 自動組裝, 鎖螺絲機

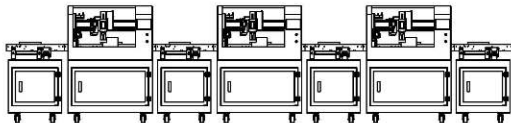
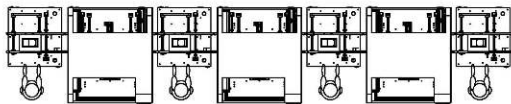
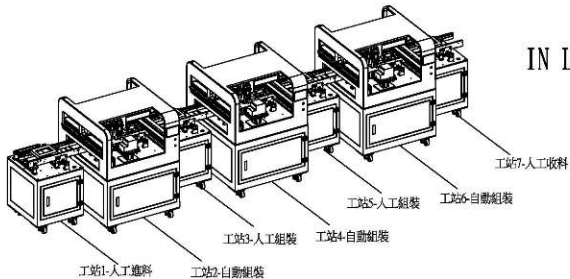

迴轉輸送帶

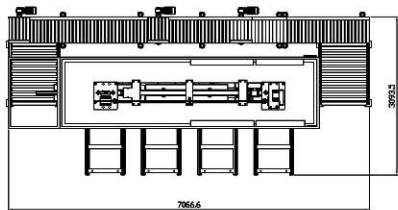

機台規格

- 一. 機台面積: 7066mm長 X 3100mm寬 X 2280mm高
- 二. 產能 : 一次產出 6 pcs
- 三. 一工序時間=15~18 秒

進料輸送帶 鑽孔機 檢測機 攻牙機 檢測機 出料輸送帶

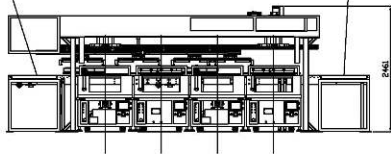

機械手

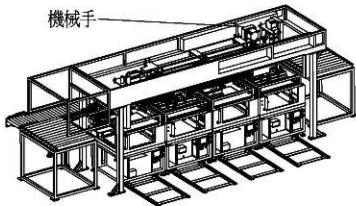

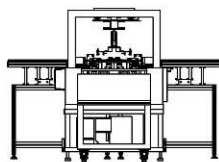
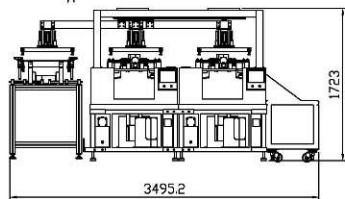
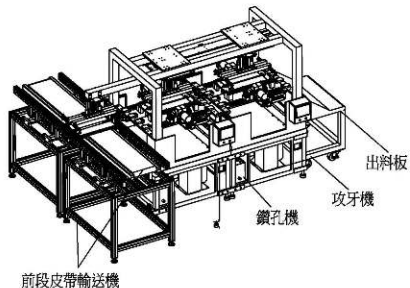
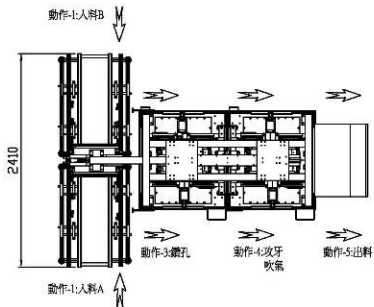

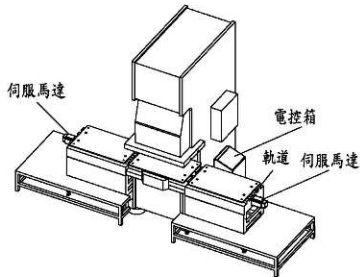
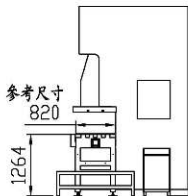
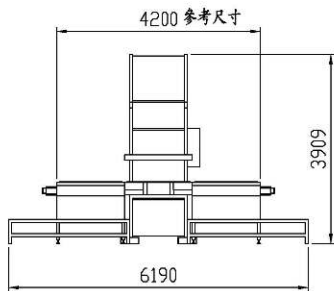
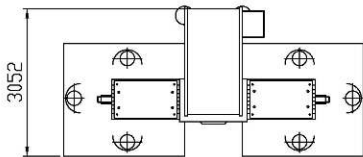

機構說明:

1. 模具左右移載, 進入沖床後, 自動卸合!
2. 下模移動, 人工將研釘放入模內
3. 本方案最大適用產品為 32"-46" (160T) 背板;
4. 左右輸送單元各一組, 裝設於沖床兩側
5. 主控制箱內嵌于左右移載臺內部
6. 操作面板與主機一體
7. 接入電源 3P 380V (50HZ)
8. 設備總功率 $\leq 10KW$
9. 理論動作時間單程 (不含人工放料) $\leq 4.5S$
10. 導向精度 $\pm 0.1mm$
11. 線性承載模具能力 $\geq 350Kg$
12. 適用衝床 160T C型 金寶/協易衝床
13. 模具數標準配置 一塊上模, 兩塊下模

P. S. 沖床及模具由客戶提供:

功能規格:

1. 手臂移載速度 1.2M/sec
2. 移載精度 = 0.05mm
3. 支援工件尺寸範圍 = 55"
4. 單支手臂可承載重量(含夾具) = 15kg
5. Z軸行程是否可調整 = 可.

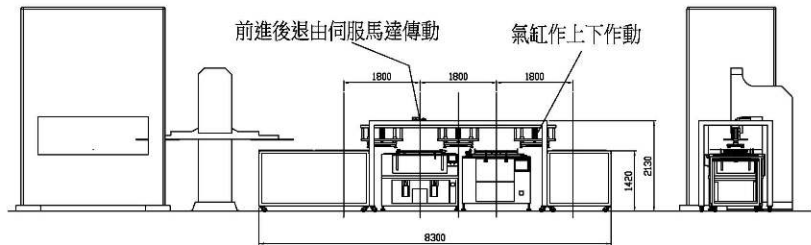
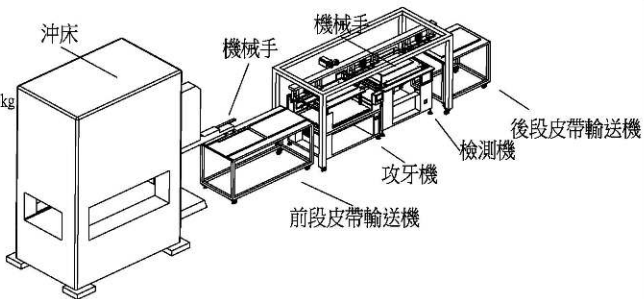

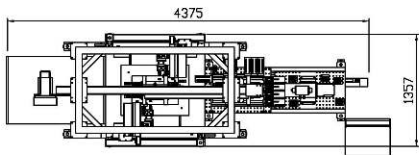

动作-3:出料

动作-2:雷焊机

动作-1:送料機

